

User Guide

MultiScreen® High Volume Filter Plate

MVHVN4525, MVFCN1225

Introduction

The MultiScreen® High Volume Filter Plate is a single-use, automation-compatible, 96-well plate with either a 0.45 µm Durapore® polyvinylidene fluoride (PVDF) membrane or a 1.2 µm Glass Fiber C (GFC) filter. This filter plate is designed to process up to 2 mL of aqueous and organic solutions, using the MultiScreen®_{HTS} Vacuum Manifold. The MultiScreen® High Volume Filter Plate is fully automation-compatible and complies with Society for Laboratory Automation and Screening (SLAS) standards (formerly SBS standards).

The 0.45 µm Durapore® PVDF filter plate offers high flow, low nonspecific binding of small molecules and proteins, low extractables (as measured by HPLC/UV), and compatibility with aqueous and some organic solutions. This filter plate can be used in a wide range of applications including low protein binding assays, low extractables assays, sample cleanup, particulate/aggregate removal (prior to HPLC or UPLC® analysis), and bead-based assays.

The 1.2 µm GFC filter plate offers broader chemical compatibility with both aqueous and organic solutions and is intended for use in applications such as lysate clearing, viscous sample filtration, bead-based assays, environmental testing, and DNA sample preparation bind-wash-elute applications.

Usage Guidelines

- For research use only.
- Single use only.
- Appropriate precautions and personal protective equipment should be used when working with flammable solvents (i.e., use adequate ventilation and avoid open flames, sparks, etc.).

- To use only a portion of the filter plate, cut a section of plate sealing film large enough to cover the wells that will not be used during the experiment (either the clean wells to be saved, or the used wells from the previous experiment).
- The liquid head height in the wells of this plate can generate far more pressure than in a standard microtiter plate, and depending on filter type and sample composition, this head height may be enough to initiate flow through the membrane and out of the flow directors (spout tips).
- Flow through the membrane may also be initiated during extended incubation. To avoid loss of sample volume during extended incubation, the filter plate should be placed on the manifold assembly, depending on your application. Cover the plate with a lid to minimize evaporation when performing extended incubations with volatile solvents.
- Maximum vacuum pressure: 677 millibar (20 in. Hg)
- Filtering samples directly from the MultiScreen® High Volume Filter Plate into another filter plate is generally not recommended.

Materials Required (Not Supplied)

- MultiScreen®_{HTS} Vacuum Manifold, MSVMHTS00
- Pipettors and/or robotic liquid handlers for handling aqueous and organic samples
- Portable vacuum pump or uniform vacuum source capable of delivering up to 677 millibar (20 in. Hg)

NOTE: MultiScreen® Standard Collar (MSVMHTS08) or the MultiScreen® Deep Well Collar (MSVMHTSOD) can be used in filter to waste.

Plate Storage

Store MultiScreen® High Volume Filter Plates at room temperature.

How to Use the MultiScreen® High Volume Filter Plate

The MultiScreen® High Volume Filter Plate is designed for use with a MultiScreen®_{HTS} Vacuum Manifold.

Assembly

Refer to the MultiScreen®_{HTS} Vacuum Manifold User Guide for manifold setup.

NOTE: If you wish to wet out the filter plate first, see the optional Pre-filtration Wetting section.

Manual Vacuum Filtration

1. Add samples to the filter plate.
2. Apply vacuum (maximum of 677 millibar [20 in. Hg]).
3. When filtration is complete, release the vacuum slowly.

NOTE: When using vacuum filtration with volatile solvents (e.g., acetonitrile), vacuum should be released as soon as filtration is complete, in order to minimize evaporation.

4. Remove the plate carefully, there may be hanging drops.
5. Clean all manifold components after use.

NOTE: When using concentrated acids it is important to flush water through the entire manifold at the end of the procedure, especially if filtrate flows through the manifold and into a flask trap.

Pre-filtration Wetting (Optional)

The MultiScreen® High Volume Filter Plate may be wet out prior to addition of samples.

1. Add 100 μ L to 2 mL of the desired reaction buffer or solvent to each well.
2. Filter the liquid through the plate, following the steps for manual vacuum filtration.
3. Do not allow the filter material to dry out after wetting.

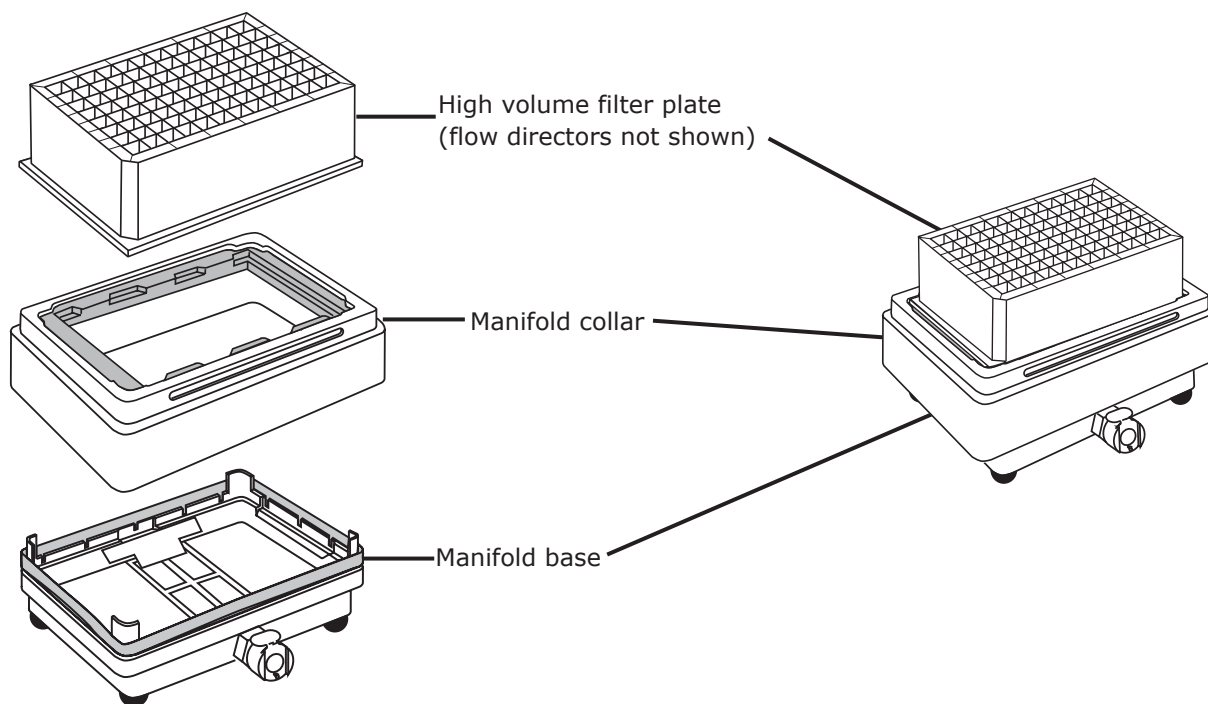

Troubleshooting

Issue: Sample flows out of plate flow directors

Possible Cause	Solution
The liquid head height in a high volume plate can generate far more pressure than in a standard microtiter plate, and depending on filter type and sample composition, this head height may be enough to initiate flow.	Place the MultiScreen® High Volume Filter Plate on top of the manifold assembly above for filtering waste. During extended incubation, place the filter plate on the manifold assembly.

Issue: Filtrate is lost or not collecting properly

Possible Cause	Solution
Incompatible components: Other brands of collection plate may not provide efficient filtrate transfer due to dimensional incompatibility with the high volume filter plate. This may lead to filtrate loss and cross-talk (well-to-well splash over).	Filter to collection is not recommended because of probability of cross-talk.

Issue: Samples are not filtering

Possible Cause	Solution
System is unable to achieve sufficient vacuum for filtration to proceed.	Confirm that the vacuum source is functioning correctly and that all of the connections are secure and leak-free. Confirm that the vacuum filtration manifold components are sealing properly (Refer to MultiScreen® _{HTS} Vacuum Manifold User Guide). Check for cracks or leaks in the filter plate. Replace plate if damaged.
Sample viscosity is too high.	Reduce viscosity by diluting the sample.
Viscosity differs from well to well, causing some wells to filter much faster, and release vacuum when empty.	Seal the top of the filter plate with plate sealing tape.
Sample particulate level is too high and has clogged the filter.	Reduce particulate level before applying sample to plate. If using the 0.45 µm PVDF filter plate, switch to the 1.2 µm GFC filter plate.
The well has air-locked. If the filter has been wet out, and the sample is applied in a manner that traps an air bubble above the filter, the sample will filter to the bubble and filtration will stop.	Apply the sample down the side of well. Remove or pop the bubble and continue filtering.

Issue: Slow filtration

Possible Cause	Solution
Wrong filter plate was selected.	The 0.45 µm PVDF filter plate (MVHVN4525) is recommended for removal of very small particles prior to HPLC or UPLC® applications. The 1.2 µm glass fiber filter plate (cat. no. MVFCN1225) is recommended for clearing lysates, viscous samples, removing large particulates, or DNA sample cleanup before binding procedures.
Plate is incompatible with sample.	Refer to Chemical Compatibility section.

Issue: The sample dissolved the filter plate or collection plate

Possible Cause	Solution
Chemical incompatibility	Use only solvents compatible with the plate materials. Refer to Chemical Compatibility section. When in doubt about compatibility of a solvent, test plate with solvent alone before applying sample.

Issue: The manifold and plate assembly does not work

Possible Cause	Solution
Incorrect assembly	Ensure that manifold has been assembled properly. Refer to Assembly section.

Specifications

Materials of construction

Filter plate	Plate	Polypropylene, high density polyethylene (HDPE)
	Filter	0.45 µm Durapore® PVDF or 1.2 µm Glass Fiber C

Sample volume per well	Recommended	2.0 mL
	Maximum	2.0 mL

Membrane surface area	23.4 mm ² (0.036 in ²)
-----------------------	---

Maximum vacuum pressure	677 millibar (20 in. Hg)
-------------------------	--------------------------

Dimensions

Filter plate	Length	127.8 mm (5.03 in.)
	Width	85.6 mm (3.37 in.)
	Height	including flow directors: 47.2 mm (1.86 in.) excluding flow directors: 44.2 mm (1.74 in.)
	Well depth	41.4 mm (1.63 in.)

Chemical Compatibility

The materials of construction for the MultiScreen® High Volume Filter Plates offer broad chemical compatibility and low levels of extractables, as analyzed by HPLC/UV. The PVDF filter plate also exhibits low nonspecific binding of small molecules and proteins. To ensure plate compatibility, we recommend pre-testing organic solvents to be used with the MultiScreen® High Volume Filter Plate under the specific conditions required by your application.

Chemical compatibility for the vacuum filtration manifold components and accessories can be found online at SigmaAldrich.com (Select Site Content, search Chem Compatibility of Materials in Millipore® Filtration).

Product Ordering

This section lists catalogue numbers for MultiScreen® High Volume Filter Plates and accessories. See Technical Assistance section for contact information. You can purchase these products online at SigmaAldrich.com.

Filter Plates	Qty/pk	Catalogue Number
MultiScreen® High Volume Filter Plate, 0.45 µm PVDF, philic, non-sterile, 2 mL	25	MVHMVN4525
MultiScreen® High Volume Filter Plate, 1.2 µm Glass Fiber C, philic, non-sterile, 2 mL	25	MVFCN1225
Accessories		
MultiScreen® _{HTS} Vacuum Manifold	1	MSVMHTS00
Standard collar (includes gasket)	1	MSVMHTS08
Deep Well Collar (includes gasket and collar gasket frame)	1	MSVMHTS0D
Chemical Duty Vacuum/Pressure Pump, 115 Volts, 60 Hz	1	WP6111560
Chemical Duty Vacuum/Pressure Pump, 220 Volts, 50 Hz	1	WP6122050
Chemical Duty Vacuum/Pressure Pump, 100 Volts, 50/60 Hz	1	WP6110060
Vacuum Flask, 1 L	1	XX1004705
Millex®-FA ₅₀ Filter	10	SLFA05010

Notice

We provide information and advice to our customers on application technologies and regulatory matters to the best of our knowledge and ability, but without obligation or liability. Existing laws and regulations are to be observed in all cases by our customers. This also applies in respect to any rights of third parties. Our information and advice do not relieve our customers of their own responsibility for checking the suitability of our products for the envisaged purpose.

The information in this document is subject to change without notice and should not be construed as a commitment by the manufacturing or selling entity, or an affiliate. We assume no responsibility for any errors that may appear in this document.

Technical Assistance

Visit the tech service page on our web site at SigmaAldrich.com/TechService.

Terms and Conditions of Sale

Warranty, use restrictions, and other conditions of sale may be found at SigmaAldrich.com/Terms.

Contact Information

For the location of the office nearest you, go to SigmaAldrich.com/Offices.

MilliporeSigma, Millipore, Multiscreen, Durapore and Sigma-Aldrich are trademarks of Merck KGaA, Darmstadt, Germany or its affiliates. All other trademarks are the property of their respective owners. Detailed information on trademarks is available via publicly accessible resources.
© 2013-2025 Merck KGaA, Darmstadt, Germany and/or its affiliates. All Rights Reserved.

The life science business of Merck KGaA, Darmstadt, Germany operates as MilliporeSigma in the U.S. and Canada.