

NovAseptic® Mixer

Mixing Head, GMP ATEX

Product Description

NovAseptic® mixers offer a complete solution for mixing throughout the process line and are designed for a wide variety of mixing applications in the pharmaceutical and biotechnology industries.

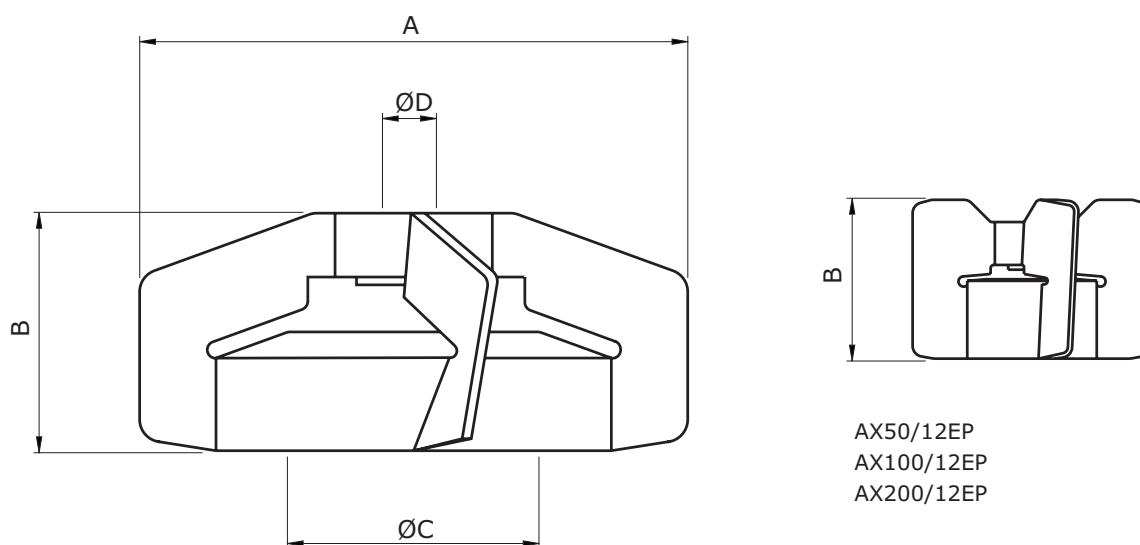

Nominal Dimensions in mm (in.)

AX###/###EP	A	B	C	D	Compatible Mixer
AX05/12EP	96 (3.78)	52 (2.05)	34 (1.34)	12 (0.47)	GMP50 ATEX
AX1/12EP	120 (4.72)	53 (2.09)	56 (2.20)	12 (0.47)	GMP100 ATEX
AX5/120EP	142 (5.59)	71 (2.80)	56 (2.20)	20 (0.79)	GMP500 ATEX
AX10/120EP	160 (6.30)	71 (2.80)	64 (2.52)	20 (0.79)	GMP1000 ATEX
AX20/12EP	184 (7.24)	73 (2.87)	87 (3.43)	20 (0.79)	GMP2000 ATEX
AX50/12EP	192 (7.56)	120 (4.72)	106 (4.17)	30 (1.18)	GMP5000 ATEX
AX100/12EP	220 (8.66)	150 (5.91)	87 (3.43)	30 (1.18)	GMP10000 ATEX
AX200/12EP	273 (10.75)	130 (5.12)	170 (6.69)	30 (1.18)	GMP20000 ATEX

Specifications

Net Weight (approximate)								
Mixing Head	AX05/12EP	AX1/12EP	AX5/120EP	AX10/12EP	AX20/12EP	AX50/12EP	AX100/12EP	AX200/12EP
Weight kg (lb)	0.5 (1.1)	0.9 (2.0)	1.3 (2.87)	1.7 (3.75)	1.8 (3.97)	3.4 (7.50)	5.1 (11.2)	6.7 (14.8)

Material					
	Bar		Plate	Female Bearing	
	Stainless steel in compliance with		Stainless steel in compliance with		Ceramic SIC
Material Code	316L	EN 1.4435	316L	EN 1.4435	Ssic

Additional Information	
Surface Roughness	Surface Ra ≤ 0.38 µm (15 µin)
Surface Treatment	Electropolished
Operating Temperature	+5 to +135 °C (+41 to +275 °F)
Note	The assembled NovAseptic® Mixer may have different design temperature and/or pressure limits. The weakest component in the assembled product determines the maximum temperature and pressure limits.
Labeling	Each Mixing Head is individually labeled for full traceability according to our QA routines.
Packaging	The Mixing Head is packaged in a closed box.
Quality Control	Our Quality Assurance System guarantees the control and traceability at all stages of the manufacturing.
pH Range	1–14
Liquid viscosity	1 to 800 cP max

The mixing head must be used with the appropriate ATEX GMP drive unit, male bearing and tank plate.

Technical Assistance

For more information, please visit [SigmaAldrich.com](https://www.SigmaAldrich.com) for up-to-date worldwide contact information

